

## Software Defined Radio – the next-generation automotive radio platform

By Harald Koch, Automotive Marketing Manager, Microtune®, Inc.

*The need for a flexible in-vehicle radio platform is growing with the expanding market for automotive "infotainment," which encompasses all of the electronic information, communications and entertainment devices inside the automobile. For multi-standard radio head-units, the deployment of advanced system architectures relying on multi-purpose DSPs could help solve design problems for automotive OEMs.*

### Current Car-Radio architecture

In order to support the various infotainment features that customers expect, such as navigation, hands-free phone control, and telematics, car radio architecture requires a large number of specialized hardware blocks that typically reside together in a single housing. For technical and economic reasons, this type of heterogeneous architecture still represents the state-of-the-art as of today. A typical mid- to high-end car radio may be visualized as follows:

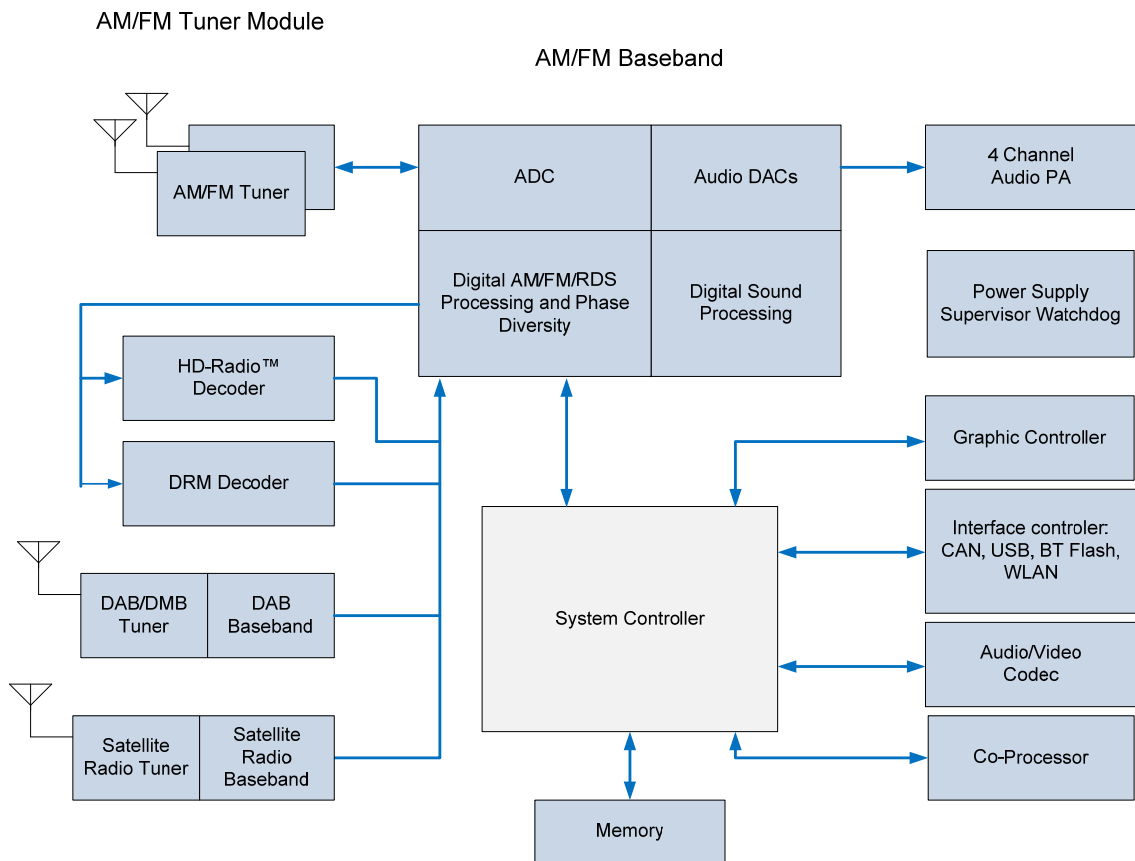

Differences in broadcasting standards require car radios to have extra tuner and decoder hardware (this is shown on the left side of the above figure) to accommodate services such as satellite radio and digital audio broadcasting (DAB)/digital multimedia broadcasting (DMB) signals. The typical design approach is to have the frontend and backend decoder on a small plug-in module which is used only in head-units that support the digital broadcasting. Since HD-Radio™ technology and Digital Radio Mondiale (DRM) are using the same frequency bands as AM/FM, they can use the same tuner and only require additional hard- and software for decoding. However, this still translates to increased costs as compared to pure analog radio reception. Designers need to consider the additional space required for these extra hardware blocks when developing car infotainment platforms for worldwide reception, even if digital radio support will only be offered as an option in some geographic areas.

In most cases the AM/FM tuners are housed in small, shielded modules to avoid interference. In mid- to high-end OEM infotainment systems, there are at least two separate AM/FM tuners and DAB receivers to enable functions like background scanning of the frequency band (to update the channel list) or to realize a phase diversity setup (which is often used to improve reception stability). So, as designs migrate to high-end infotainment systems, the available real estate challenge becomes even greater.

In addition to the operating system and user interface, the main CPU may also house the navigation system as well as audio/video decoding and controller functions for external interfaces. For high-end applications, specific co-processors are often used to unload demanding tasks from the main processor. Otherwise, the high workload would inevitably lead to a poor response of the system, which the end-customer would hardly tolerate.

Clearly, today's infotainment systems are a complex ecosystem of analog building blocks, application specific digital processors, and the respective software, which is scattered throughout the system. The key challenges facing automotive radio designers include:

- Space requirements inside a head-unit
- High bill of materials
- Excessive energy consumption and heat generation
- High design-in effort
- Limited possibility to update software
- Customer-specific hardware that cannot be re-used in other projects

## Fundamentals of Software Defined Radio

As the capabilities of analog to digital converters (ADCs) and signal processors expand, there are new ways for system designers to overcome chronic design challenges. Software defined radio (SDR) is a concept that has grown in popularity over the last few years, not only for broadcasting receivers, but also for portable mobile handsets. The principle behind SDR is to run software on a multi-purpose processor to handle the functions of the radio reception path that are typically realized in hardware, as for example, the demodulation and audio decoding. Effectively, the software defines what kind of processing is applied to the signal coming in from the antenna, enabling both analog and digital radio reception in the car radio with a minimum of components.

To fully maximize the potential of SDR, the incoming analog signal should be digitized as soon as possible, and the output signal should be converted back to analog for use by the speakers as late as possible in the process. This way costly hardware blocks can be eliminated while at the same time the flexibility is increased. Another advantage lies in the way the received signal is brought in from the antenna to the radio. The long antenna cable required in today's car radios represents a major problem as the signal faces serious degradation due to interferences in the car. Digitizing the RF signal at the antenna output, and transmitting only the digital information can improve the overall performance of the receiver.

Moving the workload from the analog to digital domain is not simple, however. True SDR for consumer applications remains a concept or 'vision' right now due to technological limitations. Digitizing the whole AM/FM band at the antenna output would mean a significant amount of data which would need to be handled and processed. The hardware required to do so is not yet available on a broad basis in the consumer electronics market so it is impossible to realize with reasonable cost and effort. As a result, designers must still use mixers to downconvert the RF signal to an intermediate frequency (IF) that can be handled. However, while limitations for ADCs etc. remain, the advanced possibilities in signal processing allows for some significant enhancements for the next generation of radio systems in the automotive electronics market.

## Software Defined Radio Architecture for In-Vehicle Infotainment Systems

As pictured on page one, today's in-car radio systems consist of many separate building blocks and a number of highly specialized processing units. There is a great potential to streamline the design by deploying multi-purpose digital signal processors (DSPs) that are powerful enough to handle not only general system controller functions but also the demodulation and decoding of different radio standards. Depending on the complexity of the system, even the graphical user interface as well as telematic applications could be handled in such a highly centralized architecture.

The difference becomes clear when drawing a block diagram of such a solution:

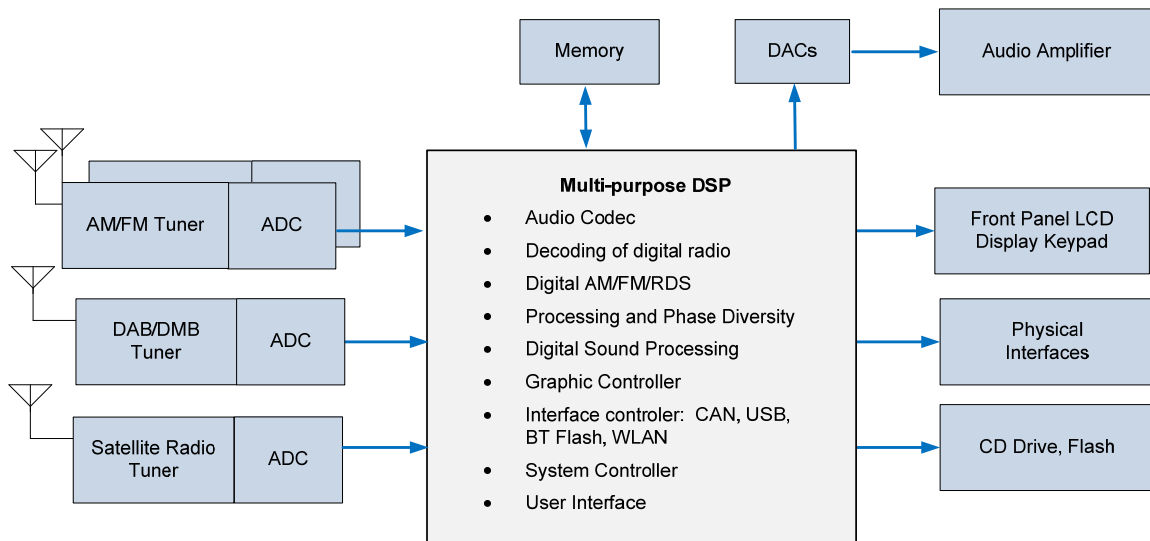

To address the specific parameters of the different broadcasting standards (frequency band, channel spacing, channel bandwidth, etc.) this platform still requires separate tuner front ends for each standard. But once the signal is digitized by the ADC, all of the signal processing can be done by a single multi-purpose DSP, saving cost as well as space in the design. The next step in shrinking the footprint would be to integrate the ADC and tuner front end, eliminating another physical building block. Also, the DAC could be eliminated with the use of a Class D power amplifier that accepts digital signals.

One of the biggest advantages of SDR is the increased flexibility gained by converting hardware blocks into software which allows the car infotainment system to be updated at the service point (such as when the customer stops by for regularly scheduled maintenance), adding new functions and removing bugs. Also, we can expect the new digital broadcasting standards to change after a few years, so the infotainment system, which is installed in an automobile with a much longer life span as compared to consumer goods, has to be easily upgradable. For example, new audio compression schemes (as currently introduced with the transition from DAB to DAB+) as well as some specific news and data services can only be supported if a particular decoder is

implemented in the receiver. With SDR, this could be achieved with a simple software upgrade. Along with that, support can be guaranteed for the latest portable media players and mobile phones over the entire lifetime of the car, which creates a real value for the end customer..

Another advantage important for system designers is that a single, future-proof hardware platform in theory could be re-used for different customer applications simply by adding application-specific software. This saves both time and cost in the design phase creating a real competitive advantage.

*Summary of advantages when using a SDR concept:*

- Reuse hardware for different customer requirements leads to reduced hardware qualification and development effort
- Software updates to fit new/changing broadcasting standards, fix bugs, support latest external devices, and not penalize early adopters
- Compact hardware platform requiring less space in the head unit
- Shorter time to market because the hardware is less complex. Development effort moves to software design while hardware stays the same for different customer requirements
- Lower bill of materials by eliminating hardware components and re-using hardware platforms
- Allows last-minute design changes because functionality is mainly determined by software

Microtune's next-generation automotive AM/FM tuner silicon



In order to support next-generation automotive infotainment platforms, Microtune introduced the RF MicroDigitizer™ MT3511, a RF-to-digital converter that combines superior performance with first-of-its-kind features to address the specific requirements of SDR platforms. For instance, the single-chip combines a silicon tuner with a 16-bit ADC providing a highly sophisticated direct interface to generic DSPs. A reference frequency output for the backend processor eliminates the need for an extra crystal.

Featuring a compact 8mm x 8mm package and a very high level of integration, the MT3511 reduces the PCB real estate required for AM/FM radio functionality by about 50%, as compared to industry-standard alternatives, without compromising performance.

The tuner integrates low noise amplifiers for AM and FM as well as programmable automatic gain control (AGC) to attenuate large input signals that could cause distortion. Digital radio standards which are broadcasted in the AM/FM frequency band as for example Digital Radio Mondiale (DRM) are supported. The MT3511 conforms to the AEC-Q100 standard, and performance is guaranteed across an extended temperature range of -40° to +85°C. As today's mid- and high-end car radios commonly include AM/FM phase diversity setups, this device features a buffered reference frequency output so that one crystal can be shared between multiple front ends and the tuners are synchronized automatically.

SUMMARY

To overcome the multiple design challenges in automotive infotainment systems, designers must use the latest technologies. The radio receiver design is ready to benefit greatly from SDR technology. With the MT3511, Microtune offers a high-performance RF-to-digital converter that supports digital radio standards, allowing system designers to use powerful generic DSPs to reduce the complexity, size, and cost of multi-standard receiver systems.

Copyright © 2008 Microtune, Inc. All rights reserved. Microtune is a registered trademark and MicroTuner is a trademark of Microtune, Inc. All other company and/or product names may be trade names, trademarks and/or registered trademarks of the respective owners with which they are associated. HD Radio™ technology manufactured under license from iBiquity Digital Corp. U.S. and foreign patents. The HD and HD Radio logos are proprietary trademarks of iBiquity Digital Corp.