



M I C R O T U N E ®

RF SILICON AND SUBSYSTEMS SOLUTIONS
FOR BROADBAND COMMUNICATIONS AND AUTOMOTIVE ELECTRONICS

MT2170 SINGLE-CHIP DOCSIS 3.0 WIDEBAND TUNER

PRODUCT BRIEF

The MT2170 is a low-power, single-chip DOCSIS 3.0 wideband tuner with an integrated IF variable gain amplifier.



MT2170 Single-Chip
DOCSIS 3.0 Wideband Tuner

The MicroTuner™ MT2170 is an advanced, low-power single-chip wideband tuner that has been optimized for high-performance DOCSIS 3.0-compliant cable modems and digital cable set-top boxes that require low composite distortion and low noise under digital cable environments.

The MT2170 is capable of receiving frequencies in the 48 MHz to 1 GHz range and of converting a selected channel to a standard intermediate frequency (IF) between 26 MHz and 122 MHz.

The MT2170's dual-conversion architecture yields the desirable characteristics of DOCSIS 3.0 broadband functionality. Together with the Microtune differential 2nd IF Filter, the MT2170 provides an optimized IF signal needed for DOCSIS 3.0 demodulators.

The MT2170 provides excellent in-band flatness as well as very repeatable gain characteristics across the complete reception band.

The MT2170 has a field proven, onboard, fully autonomous AGC which requires only one signal connection between the tuner and the demodulator. This allows signals of poor quality to be adequately conditioned for further processing to deliver extremely low bit error rates.

APPLICATIONS

- DOCSIS 3.0 Wideband Cable Modems
- Video over IP Digital Set-top Boxes
- DOCSIS 3.0 VoIP Telephony Modem
- PacketCable™ E-MTA's
- Home Gateways
- Multimedia Applications

FEATURES

- 48MHz to 1GHz input frequency range
- 5 V and 3.3 V power supply
- Works seamlessly with DOCSIS 3.0 digital demodulators
- 1.5 W typical dual-conversion architecture
- Single-ended RF input reduces BOM by eliminating input balun
- Minimal external components
- No manually tunable parts required
- Integrated IF variable gain amplifier for direct connection to digital demodulators
- Fully compatible with DOCSIS 3.0, EuroDOCSIS 3.0, and other standards

M I C R O T U N E

MT2170 SINGLE-CHIP WIDEBAND TUNER

PRODUCT BRIEF

RECOMMENDED OPERATING CONDITIONS

PARAMETER	MIN	TYP	MAX	UNIT
Second intermediate center frequency (programmable)	26		122	MHz
Supply voltage 5V	4.75	5.0	5.25	V
Supply voltage 3.3V	3.15	3.3	3.45	V
Supply voltage ripple			15	mV
Operating junction temperature			125	°C
VGA output load impedance	500			Ω
Serial control clock			400	kHz

ABSOLUTE RATINGS

PARAMETER	MIN	MAX	UNIT
Supply voltage 5V		6	V
Supply voltage 3.3V		3.6	V
Storage temperature range	-50	+150	°C
Lead-free temperature (soldering 4 seconds)		+260	°C
Input voltage	-0.3	VCC +0.3	V

TUNER ELECTRICAL CHARACTERISTICS

PARAMETER	MIN	TYP	MAX	UNIT
Power Supply				
Active current 5V			270	mA
Active current 3.3V			85	mA
RF Signal Path				
Input frequency range	48		1000	MHz
Noise figure		9		dB
Voltage gain		42		dB
RF AGC range		55		dB
Image rejection		70		dBc
LO phase noise (10 kHz)		84		dBc/Hz
LO phase noise (100 kHz)		104		dBc/Hz
LO step size		50		kHz
IF VGA				
Frequency range	26		126	MHz
Maximum output voltage			1.0	Vp-p
Maximum voltage gain		30		dB
IF AGC range		46		dB

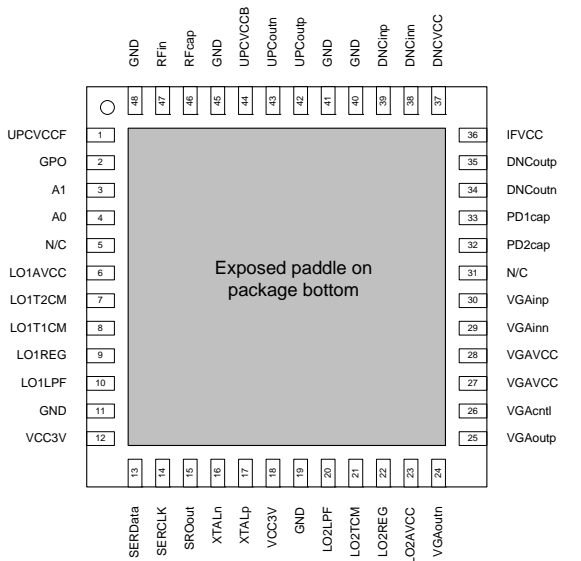

MT2170 Pin Diagram

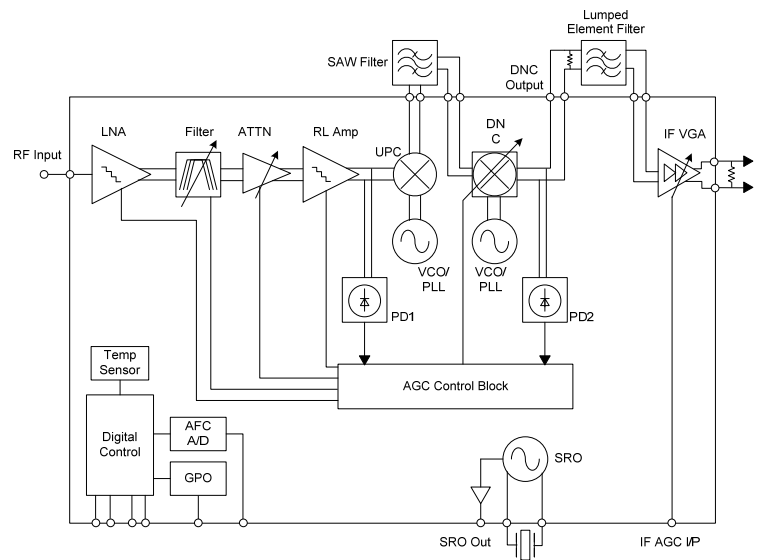

MT2170 Block Diagram



Microtune, Inc., 2201 10th Street, Plano, TX 75074, USA

Tel: +1-972-673-1600, Fax: +1-972-673-1602, E-mail: sales@microtune.com, Web site: www.microtune.com

For a detailed list of office locations, sales offices, and sales representatives, visit our web site at www.microtune.com

Microtune believes that the information in this document is accurate and reliable, as of the date of this document. Microtune assumes no responsibility for any consequences arising from the use of this information, nor from any infringement of patents or the rights of third parties which may result from its use. No license is granted by implication or otherwise under any patent or other rights of Microtune. The information in this publication replaces and supersedes all information previously supplied, and is subject to change without notice. The customer is responsible for assuring that proper design and operating safeguards are observed to minimize inherent and procedural hazards. Microtune assumes no responsibility for applications assistance or customer product design.

The devices described in this document are not authorized for use in medical, life-support equipment, or any other application involving a potential risk of severe property or environmental damage, personal injury, or death without prior express written approval of Microtune. Any such use is understood to be entirely at the user's risk.

Microtune is a registered trademark of Microtune, Inc. MicroTuner, MicroStreamer, VideoCaster, DataCaster, ClearTune, and the Microtune logo are trademarks of Microtune, Inc. All other trademarks belong to their respective companies.

Microtune's products are protected by one or more of the following U.S. patents: 5,625,325; 5,648,744; 5,717,730; 5,737,035C1; 5,739,730; 5,805,988; 5,847,612; 6,100,761; 6,104,242; 6,163,684; 6,169,569; 6,172,378; 6,177,964; 6,211,745; 6,218,899; 6,268,778; 6,310,387; 6,323,736; 6,355,537; 6,429,502; 6,462,327; 6,535,068; 6,580,313; 6,608,522; 6,631,257; 6,714,776; 6,725,463; 6,744,308; 6,771,124; 6,784,945; 6,804,099; 6,888,406; 6,891,435; 6,906,594; 6,909,886; 6,919,774; 6,920,182; 6,922,556; 6,963,478; 6,973,288; 6,993,310; 7,035,614; 7,039,062; 7,078,960; 7,079,195; 7,119,834; 7,164,899; 7,171,176; 7,184,724; 7,190,942; 7,190,943; 7,242,918; 7,274,410; 7,304,689; 7,304,533; 7,304,393; 7,313,201; 7,319,849; 7,333,791; 7,359,686; 7,369,827; 7,376,407; 7,388,437; 7,436,262; 7,444,126; 7,446,692; D469,742 and additional patents pending or filed.

Microtune's products are protected by one or more of the following International patents:

United Kingdom: 125700; 1532732; Germany: 602298894.6; 60313621.4; Netherlands: 1225700; 1532732; France: 1225700; 1532732; and additional patents pending or filed.

Entire contents Copyright © 1996 - 2009 Microtune, Inc.

011609