



M I C R O T U N E ®

RF SILICON AND SUBSYSTEMS SOLUTIONS
FOR BROADBAND COMMUNICATIONS AND AUTOMOTIVE ELECTRONICS

MT2266 SINGLE-CHIP DUAL-BAND LOW-POWER DVB-T / DVB-H TUNER

PRODUCT BRIEF

The MT2266 is a direct conversion low-power single-chip broadband tuner for VHF Band III and UHF applications.



MT2266 Single Chip Dual-Band Tuner

PRELIMINARY

The MicroTuner™ MT2266 is a direct conversion, low-power, single-chip broadband tuner optimized for UHF and VHF Band III DVB-T and DVB-H applications. It includes all active circuitry required to implement the complete RF-to-Baseband tuner function.

The MT2266 has been developed to give manufacturers design flexibility and low operating power, at low cost, without compromising high performance.

The MT2266 is capable of receiving UHF band and VHF Band III frequencies, enabling manufacturers to target low-power portable and low-power PCTV devices.

The combination of power management, choice of architecture, and Microtune's patents-pending ClearTune filtering technology enables the MT2266 to operate at 325 mW.

High-volume consumer markets demand low-cost products. The MT2266 was designed for low cost. The single-ended direct conversion architecture eliminates the need for baluns at the RF inputs and costly IF SAW filters. To further reduce cost and power, the UHF and VHF Band III variable gain low noise amplifiers (VLNA) and the voltage controlled oscillators (VCO) are fully integrated.

The transmission environment for mobile TV is extremely hostile. Microtune's unique patents-pending ClearTune filtering technology and the excellent performance of MT2266 will help to ensure that end users will have a superior mobile TV experience without picture interruption in the middle of tall buildings or hostile radio environments.

APPLICATIONS

- Portable DVB-T receivers
- PC-TV
- Notebook computer
- Dual-standard (DVB-T/DVB-H) media platforms
- Personal multimedia consoles
- PDA TV
- General DVB-T TV applications

FEATURES

- Fully compliant with NorDig Unified V1.0.2 and MBRAI specifications
- Integrated variable gain low noise amplifier (VLNA)
- Integrated voltage controlled oscillator (VCO)
- No RF input balun required
- No IF SAW filters required
- Low cost BOM
- 470 MHz to 862 MHz UHF frequency range
- 174 MHz to 230 MHz VHF band III frequency range
- 2.7V power supply
- Multiple power-down options
- Direct demodulator interface
- Minimal external components
- No tunable parts required
- Low phase noise for excellent COFDM performance
- One general purpose output controllable via serial control interface
- Operation with a crystal range of 8-38.4 MHz
- Crystal Oscillator LVDS or CMOS output for driving a DVB-T demodulator
- Small 6mm x 6mm 40-pin QFN package

M I C R O T U N E

RECOMMENDED OPERATING CONDITIONS

PARAMETER	MIN	TYP	MAX	UNIT
UHF input frequency range	470		862	MHz
VHF III input frequency range ¹	174		230	MHz
Supply voltage	2.6	2.7	3.0	V
Supply voltage ripple			15	mV
Operating junction temperature	0		100	°C

1. Will also support operation at other VHF III frequency ranges with external components change.

ABSOLUTE RATINGS

PARAMETER	MIN	MAX	UNIT
Supply voltage		3.6	V
Storage temperature	-50	150	°C
Lead-free solder temperature for 5 seconds		260	°C
Relative humidity		95	%

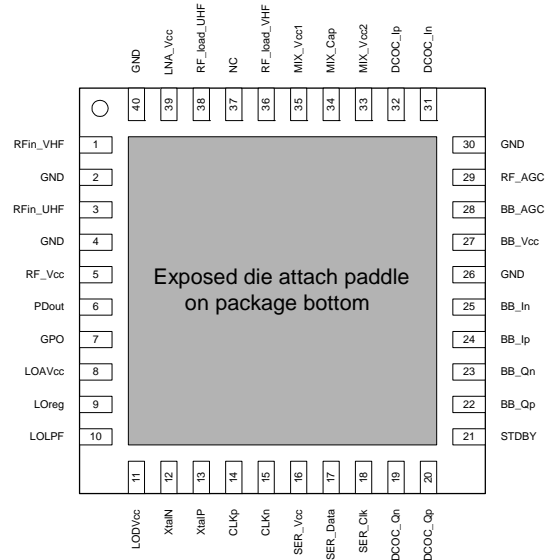

MT2266 Pin Diagram

PRELIMINARY

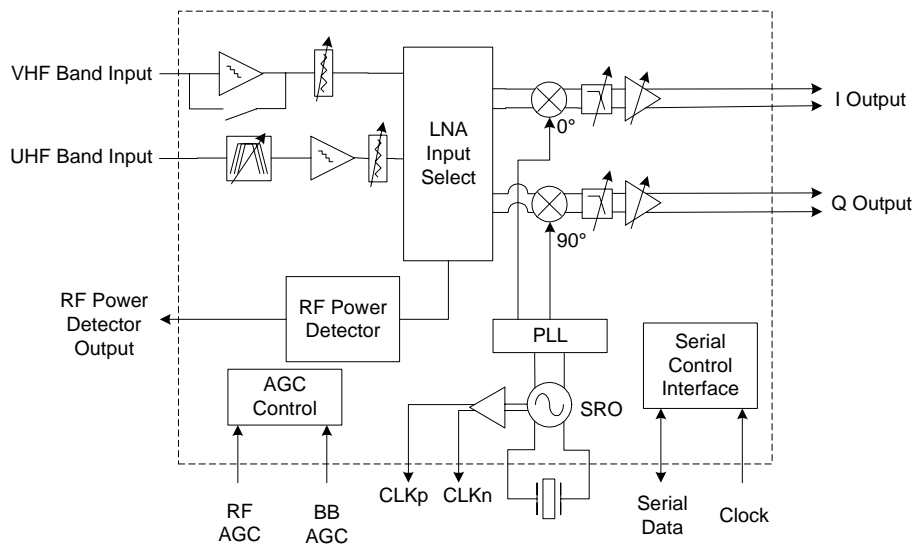

MT2266 Block Diagram



Microtune, Inc., 2201 Tenth Street, Plano, TX 75074, USA

Tel: +1-972-673-1600, Fax: +1-972-673-1602, E-mail: sales@microtune.com, Web site: www.microtune.com

For a detailed list of design centers, sales offices, and sales representatives, visit our Web site at www.microtune.com

The information in this document is believed to be accurate and reliable. Microtune assumes no responsibility for any consequences arising from the use of this information, nor from any infringement of patents or the rights of third parties which may result from its use. No license is granted by implication or otherwise under any patent or other rights of Microtune. The information in this publication replaces and supersedes all information previously supplied, and is subject to change without notice. The customer is responsible for assuring that proper design and operating safeguards are observed to minimize inherent and procedural hazards. Microtune assumes no responsibility for applications assistance or customer product design.

The devices described in this document are not authorized for use in medical, life-support equipment, or any other application involving a potential risk of severe property or environmental damage, personal injury, or death without prior express written approval of Microtune. Any such use is understood to be entirely at the user's risk.

Microtune is a registered trademark of Microtune, Inc. MicroTuner, MicroStreamer, VideoCaster, DataCaster, and the Microtune logo are trademarks of Microtune, Inc. All other trademarks belong to their respective companies.

Microtune's products are protected by one or more of the following U.S. patents: 5,625,325; 5,648,744; 5,717,730; 5,737,035; 5,739,730; 5,805,988; 5,847,612; 6,100,761; 6,104,242; 6,144,402; 6,163,684; 6,169,569; 6,172,378; 6,177,964; 6,211,745; 6,218,899; 6,268,778; 6,310,387; 6,323,726; 6,355,537; 6,429,502; 6,462,327; D469,742; 6,535,068; 6,580,313; 6,608,522; 6,631,257; 6,674,409; 6,714,776; 6,725,463; 6,744,308 B1; 6,771,124; 6,784,945; 6,804,099; 6,888,406; 6,891,435; 6,906,594; 6,920,182; 6,963,478; 6,973,288; D,469,742; DE10,011,662 and additional patents pending or filed.

Entire contents Copyright © 1996 - 2006 Microtune, Inc.

121505